

Size:427mm×150mm×130mm

Motor:Capacitor induction

Bearing:Ball

Impeller:Reinforced Plastic, $\varnothing 91\text{mm} \times 320\text{mm}$

Frame:Steel with plastic-coated

Weight:2.7kg

Life:30000hours

Operation Temperature:-20°C ~ +50°C

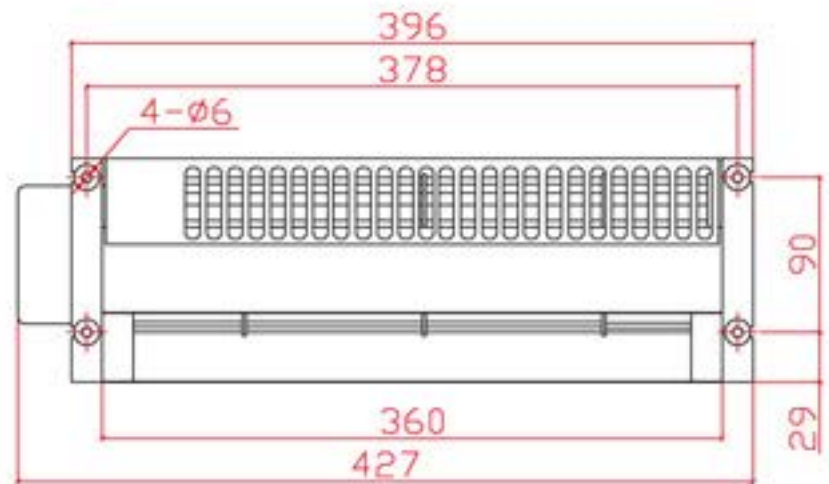

Model	Voltage VAC	Freq. Hz	Current A	Power W	Speed RPM	Air flow m ³ /hr	Noise dB
ZFB-1035	110	50/60	0.21/0.26	23/28	1230/1260	315/320	≤47
	230		0.11/0.14	24/30	1230/1280	315/325	≤47

